

## G23B Series

### Motor Electronic Lock for Onboard AC Charging Socket



#### ■ Features

- High-density sealed motor electronic lock, meeting IP54 requirements
- Reliable locking, manual and automatic unlocking are available
- Accurate locking or unlocking positioning and clear gear
- The motor electronic lock is sensitive to forward and reverse conversion, with long service life, stable and reliable

#### ■ Application

- ◆ Charging Gun

#### ■ Parameters

Rated Voltage	12VDC (pulse)	
Voltage Range	12±10% VDC.	
Motor No Load Current	≤50mA	
Motor Lock Current	≤500mA	
Response Time	≤100mS	
Maximum Power on Time	3S (No long time conduction)	
Locking Time	≤300mS	
Unlocking Time	≤300mS	
Triggering Time at 12VDC	0.25S<t<1S	
Functional Angle	≤90°	
Insulation Resistance	100MΩ Min	
Dielectric Strength	500VAC (50~60Hz)	
Degree of Protection	IEC IP54 Except driving wheel and push rod active cavity	
Operating Temperature	-40°C~+85°C	
Operating Humidity	45%RH~85%RH	
Service Life	Electrical	30,000 cycles
	Mechanical	30,000 cycles (Min.)
Operating Frequency	Electrical	18 cycles/min
	Mechanical	18 cycles/min
Operating Features (At 12VDC)	HF	300g (Min.)
	Fracture Force	200N
	PT	8.0mm±0.20mm
	OF	300g.cm (Min.)

### G23B Series Motor Electronic Lock Ordering Model Guide

G23B	Electronic Lock Series	G23B Series Motor Electronic Lock	
		500	Torque
A	Terminal Spec.	A	26# AWG
		B	24# AWG
B	Feedback Switch Function	A	NC
		B	NO
1	Manual Unlocking Knob Type	00	None
		01	Triangle knob
A	Wire Type	A	UL2464
		B	UL2463
300	Wire Length	000	None
		300	300mm Wire Length Motor Positive Red Wire Negative Black Feedback switch COM terminal with blue wire and NC terminal with green wire (NO terminal with orange wire)
T001	Custom Code	General	Customized according to requirements, the code format is T+ serial number XXX for example: T001
		T0 01	Other
U	LOGO	U	Unionwell
		...	Other
500	Torque	500	500g.cm (Min.)
		...	Other
C	Terminal Spec.	C	22# AWG
		D	20# AWG
B	Feedback Switch Function	C	(DT)
		...	Other
1	Manual Unlocking Knob Type	02	"-" Type manual unlocking wrench
		...	Other
A	Wire Type	C	UL2096
		D	UL2099
300	Wire Length	500	500mm Wire Length Motor Positive Red Wire Negative Black Feedback switch COM terminal with blue wire and NC terminal with green wire (NO terminal with orange wire)
		...	Other
T001	Custom Code	General	Customized according to requirements, the code format is T+ serial number XXX for example: T001
		T0 01	Other
U	LOGO	U	Unionwell
		...	Other

# Unionwell

## Basic Overall Dimensions and Installation Dimensions

### G23B

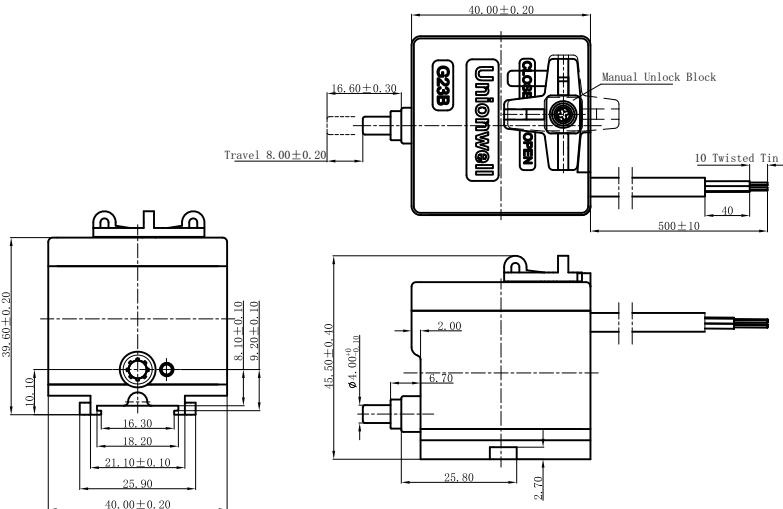

## Manual Unlocking Wrench Type

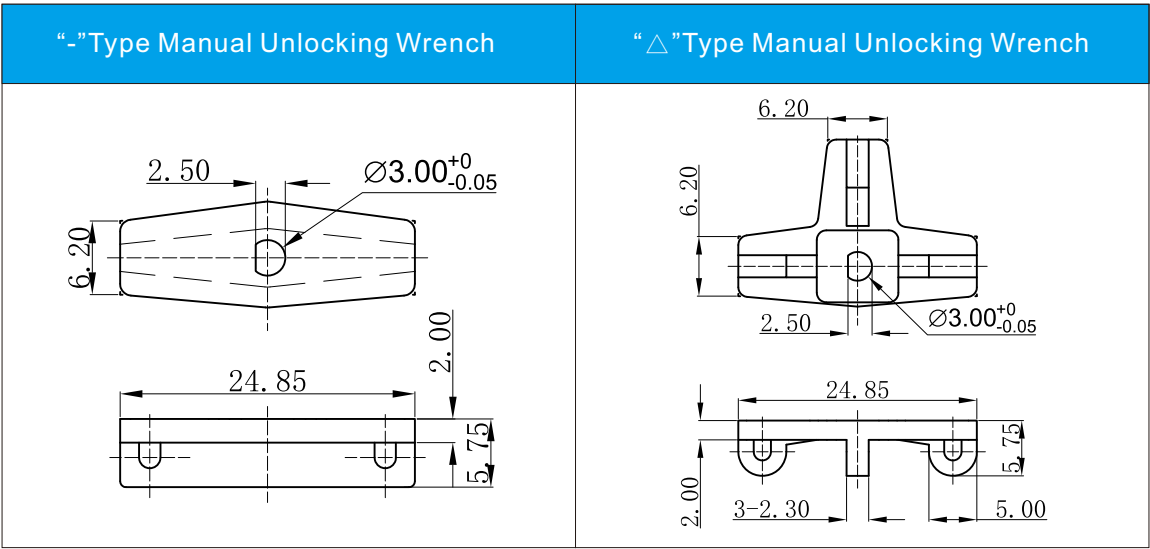

# Unionwell

## Feedback Switch Function / Mechanical Switch

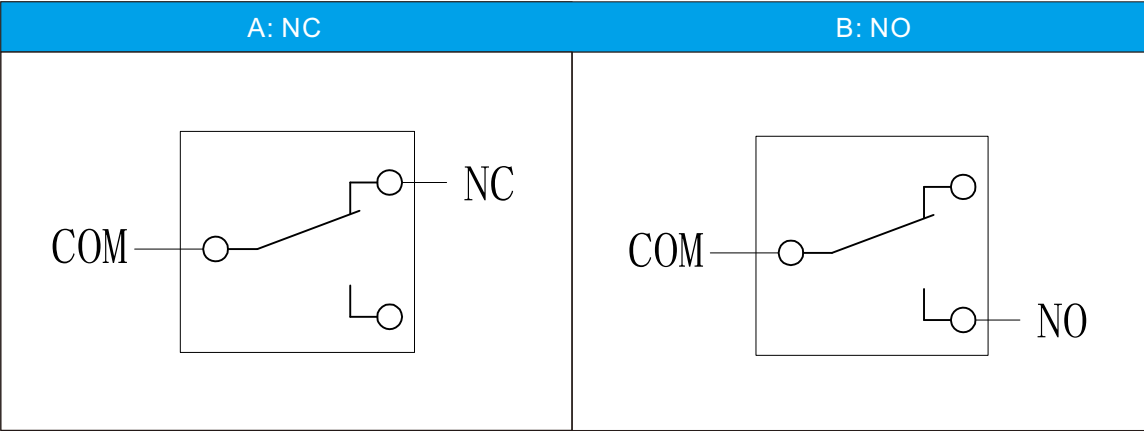

## Dimensions and Operating Characteristics

◆ G23B-500BA01A300U

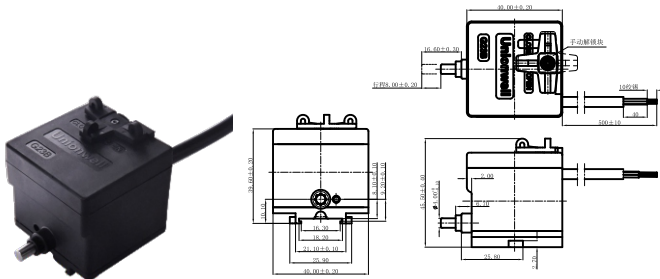

HF	PT	Rotary Shaft Strength	OF
30N.cm (Min)	8.0±0.2 (mm)	200N Vertical Axial Force Without Mechanical Damage	50N.cm (Min)